

MODEL	FILL	CAPACITY
700C-2P	2" MPT	20 Gallons
700C-3P	3" MPT	20 Gallons
700C-4P	4" MPT	20 Gallons
750C-2P	2" FPT	20 Gallons
750C-3P	3" FPT	20 Gallons
750C-4P	4" FPT	20 Gallons
770C-2P**	2" comp.boot	20 Gallons
770C-3P**	3" comp.boot	20 Gallons
770C-4P**	4" comp.boot	20 Gallons

S Following any model no. designates stainless steel construction
 **Cutout and bolt holes pre-drilled for UL Listed flexible entry boot (supplied with unit)

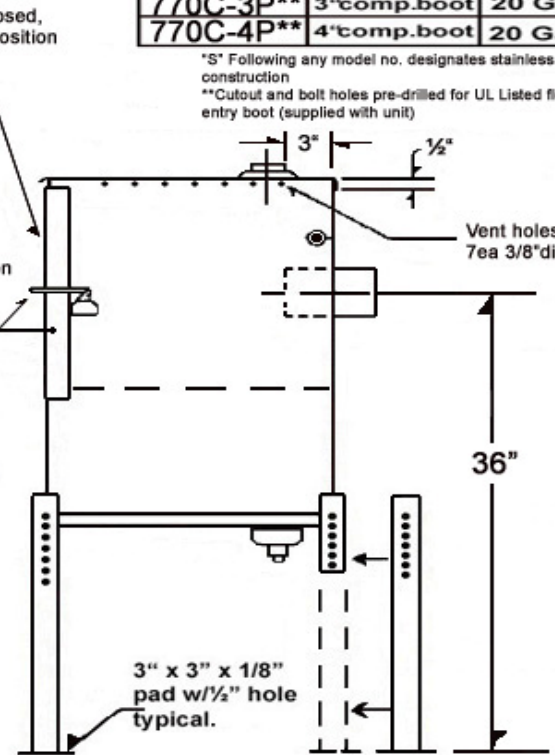

MATERIALS:

- **SPILL CONTAINMENT CABINET:**
16GA STEEL MINIMUM (ALT "S"-16GA MINIMUM STAINLESS STEEL)
- **LEGS AND STUBS:**
1½" X 1/8" STEEL ANGLE (ALT "S" 1½" X 1½" X 1/8" STAINLESS STEEL)
- **FILL AND DRAIN PIPE FITTINGS:**
ALL STEEL, SCH 40 MIN (ALT "S" S/S, SCH 40 MIN)
- **LOCK TABS:**
3/16" STEEL WITH ½" DIA PADLOCK HOLE (ALT "S" 3/16" STAINLESS STEEL)
- **COATING:**
POWDERCOAT EPOXY FINISH INTERIOR AND EXTERIOR (ALT "S" BARE STAINLESS STEEL, NO COATING)

CAUTION

FLAMMABLE OR COMBUSTIBLE LIQUIDS/VAPORS MAY BE PRESENT. KEEP AWAY SPARKS, FLAME, IGNITION SOURCES. EXTINGUISH SMOKING MATERIALS. FOR USE WITH PROPERLY VENTED STORAGE VESSELS. KEEP DOOR CLOSED AND LOCKED WHEN NOT IN USE.

This drawing and design are proprietary to BAKER INDUSTRIES NORTHWEST, and may not be copied or duplicated in whole or in part without the written permission of BAKER INDUSTRIES NW.

**#700 SERIES GROUND LEVEL SPILL CONTAINMENT
 MULTIPLE COMPARTMENT MODELS WITH LEGS FOR BOLTING TO FOUNDATION**

BAKER INDUSTRIES NORTHWEST

12428 Highway 99 South, Unit 56
 Everett, Washington 98204-5502

Tel:(425)212-3169 • FAX:(425)353-6788 • e-mail: larry@bakerindnw.com
www.bakerindustriestnorthwest.com

REV	DESCRIPTION	DRAWN	CHECKED	DATE
REV		LRG	RBW	03-28-95
REV		SLG	LRG	03-05-06
REV				

